



Product Information

REFLEX

AC/ACi
RR B/E C, CC



Reach Truck for Coldstore Applications

BT REFLEX Coldstore Reach Trucks are designed for operation in temperatures as low as -35° and are available with a full range of capacities up to 2500kg, and with lift heights up to 11.5m. Each truck is configured to provide the optimum chassis/battery/mast combination to suit the requirements of the application.

All the features from the standard REFLEX truck are included in the cold store trucks, plus:

- All microswitches, electrical components (including steering system) and motor are designed to work under cold store conditions.
- The hydraulic system's air supply is filtered to remove moisture.
- The hydraulic system contains dedicated cold store oil.
- All stressed fabrications, such as mast, fork carriage and extending carriage are specially checked at all welded joints.
- All exposed axles and springs are either made of stainless steel or treated to work under cold store conditions.
- All sheet metal components are protected by powder paint.
- Machined surfaces are protected by anti-rust covering (Tectyl).
- The floor, steps and pedals have a non-slip covering.

Options

- Electrically heated seat (textile or leather imitation), equipped with a thermostat (range $+14^{\circ}\text{C}$ — $+28^{\circ}\text{C}$).

Cold store version with open cab

- Key switch and travel direction switch are upgraded to sealed versions.

Cold store version with sealed cab

- Fully enclosed heated driver's cab, with automatic tilt facility for maximum visibility. Tilt-back and tilt-forward can be programmed to activate at different heights. The tilting cab provides excellent accessibility for servicing. Also available in a non tilting version.
- Large plexi-glass windows give maximum visibility, even in the overhead guard. The roof also contains an emergency exit.
- Inside the cab there are no exposed metal parts.
- A thermostat regulates air temperature. The heater runs constantly at 1500W, with a time-relay controlled boost to 3000W. Air controlled de-misting function.



Technical details and Measurements according to RR B/E, except for:

Dimensions with cab, mm	RR B/E 2—3 CC ¹⁾	RR B/E 4—6 CC	RR B/E 7—8 CC
h_6 Height of cab	2180	2245	2245
W_a Turning radius	1690	1735	1856
l_7 Truck length excl. fork	1862	1937	2062

1) Cold store cabin **neither** for RR B/E 1 **nor** RR N 1—3

Minimum battery width 344mm (480Ah).

Truck performance and dimensions are nominal and subject to tolerances.
 BT Products AB products and specifications are subject to change without notice.
 All data is based on VDI 2198.

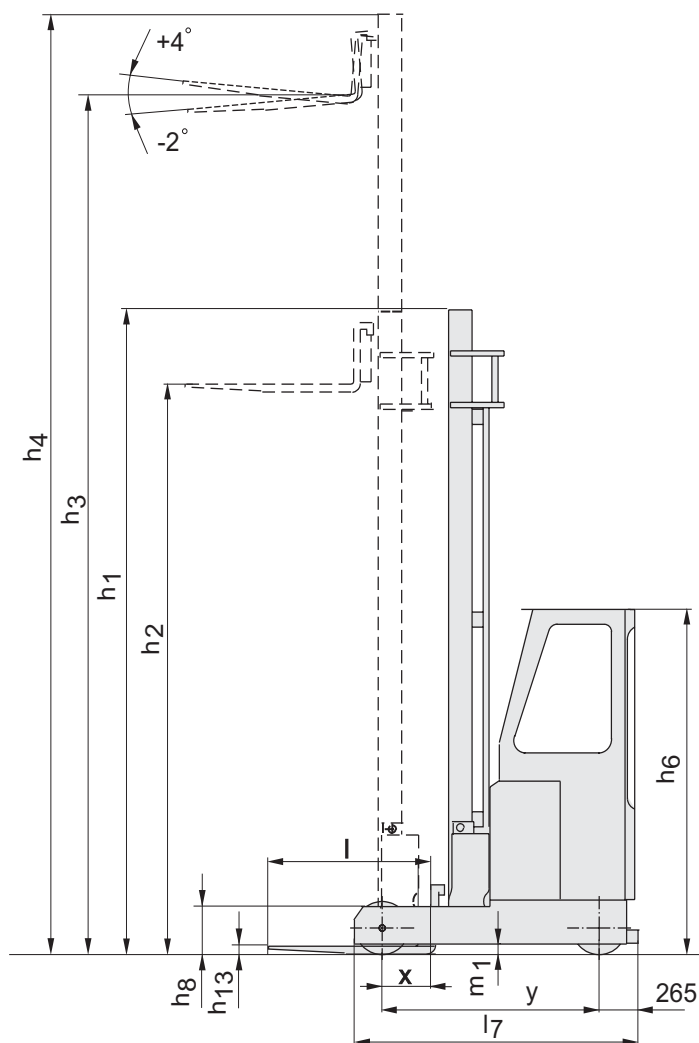

BT Europe AB, SSD, Sweden — 747502-040, 0303

BT
 SE-595 81 Mjölby Sweden
 Tel: +46 - (0)142 860 00
 Fax: +46 (0) 142 866 00
 Email: info@bt-forklifts.com
www.bt-forklifts.com



Handling innovation