

C4E250NV  
C4E300NV



The new C4E250NV-300NV range combines the manoeuvrability typical of a truck with battery above the rear axle (shorter total length) with the advantages of asynchronous drive. Its characteristics make it ideal for operation in tight spaces with frequent lifting, even to very high levels.



Technical Details		C4E250NV	C4E300NV
Power unit		electric	electric
Operating type		driver seated	driver seated
Rated capacity	kg	2500	3000
Load centre	mm	500	500
Load per axle without load, front/rear	kg	2175/2655	2575/2735
Load per axle with load, front/rear	kg	6350/980	7490/820
Number of wheels, front/rear		2-4/2	2/2
Wheel type, front/rear <sup>2)</sup>		C/SE/PN/SE.TW/PN.TW	C/SE
dimension, front		559x203/23x9-10/23x9-10/ 6,50-10/6,50-10	559x229/23x10-12
dimension, rear		457x152/18x7-8/18x7-8	457x152/18x7-8
Centre of wheels, front	mm	929/938/938/1175/1175	911/940
Centre of wheels, rear	mm	858/860/860	858/860
Fork arm carriage acc. to ISO-FEM		II A	III A
Travel speed, without/with rated load	km/h	16,5/16,0	16,5/15,5
Service brake		hydraulic	hydraulic
Parking brake		hand brake	hand brake
Lift speed, without/with rated load	m/s	0,47/0,34	0,47/0,32
Lowering speed, without/with rated load	m/s	< 0,60	< 0,60
Nom. drawbar pull, without/with load	N	7100/6700	7000/6400
Max. drawbar pull, without/with load (S2 5')	N	12700/12200	12600/12000
Gradient, without/with rated load (S2 30')	%	10,0/7,6	9,4/6,6
Max. gradient, without/with rated load (S2 5')	%	22,8/15,2	20,3/13,6
Drive motor	kW	14	14
Lift motor	kW	14	14
Battery capacity	V/Ah	80/540-630	80/630-735
Battery weight	kg	1653	1904
Weight with battery	kg	4830	5310
Steering system		hydraulic	hydraulic
Speed control		AC Mosfet	AC Mosfet
Working pressure for attachments	bar	150	150

Dimensions, mm		C4E250NV	C4E300NV
x	Front axle to fork face	442 <sup>2)</sup>	447 <sup>2)</sup>
y	Wheel base	1390	1540
$\alpha/\beta$	Mast tilt forward/backward	2°30'/6°	2°30'/6°
h <sub>6</sub>	Height overhead guard	2307	2307
h <sub>7</sub>	Height of driver's seat	1231	1231
l <sub>2</sub>	Truck length incl. back of fork	2152 <sup>2)</sup>	2152 <sup>2)</sup>
b <sub>1</sub>	Chassis, width	1112/1145/1145/1490/1490	1140/1188
s	Fork thickness	40	45
e	Fork width	120	120
l	Fork length	1000	1000
m <sub>1</sub>	Floor clearance under mast	106	106
m <sub>2</sub>	Floor clearance mid wheelbase	116	116
A <sub>st</sub>	Aisle width, mm		
	Pallet size 800x1200/1000x1200 <sup>3)</sup>	3856/3656 <sup>2)</sup>	4005/3805 <sup>2)</sup>
W <sub>a</sub>	Turning radius	2014	2158

1) C = Cushion, SE = Superelastic, PN = Pneumatic, TW = Twin

2) With side shift = +34mm

3) Shortside handling / longside handling

Mast, mm	Duplex			Duplex FFL			Triplex			Triplex FFL		
<b>h<sub>3</sub> Lift height</b>	<b>3160</b>	<b>3660</b>	<b>4160</b>	<b>3160</b>	<b>3660</b>	<b>4160</b>	<b>4965</b>	<b>5565</b>	<b>6060</b>	<b>4960</b>	<b>5560</b>	<b>6060</b>
<b>C4E250NV</b>												
h <sub>1</sub> Height of mast, min.	2225	2475	2725	2225	2475	2725	2325	2525	2725	2325	2525	2725
h <sub>2</sub> Free lift	0	0	0	1556	1806	2056	0	0	0	1656	1856	2056
h <sub>4</sub> Height of mast, max.	3829	4329	4829	3829	4329	4829	5635	6235	6765	5629	6226	6729
<b>C4E300NV</b>												
h <sub>1</sub> Height of mast, min.	2225	2475	2725	2225	2475	2725	2325	2525	2725	2325	2525	2725
h <sub>2</sub> Free lift	0	0	0	1552	1802	2052	0	0	0	1652	1852	2052
h <sub>4</sub> Height of mast, max.	3833	4333	4833	3833	4333	4833	5638	6238	6765	5633	6233	6733

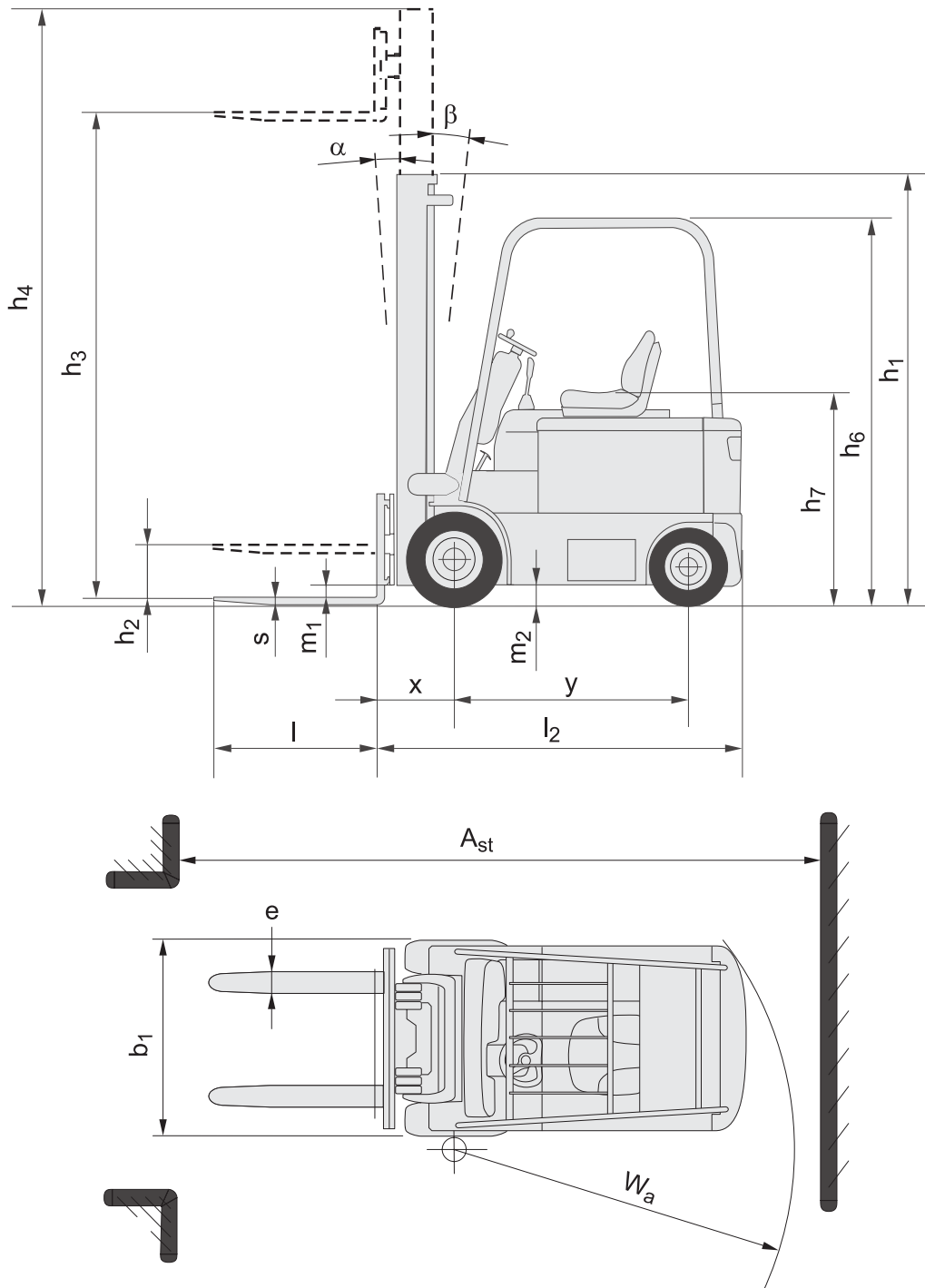

Truck performance and dimensions are nominal and subject to tolerances.  
 BT Products AB products and specifications are subject to change without notice.  
 All data is based on VDI 2198.



- Asynchronous drive ensures quick direction changes, smooth acceleration and outstanding efficiency. The low power consumption and the capability for using high-capacity batteries give the machine exceptional autonomy of operation. It also allows the truck to be held on ramps without engaging the brakes
- The operator has a choice of different driving modes, selected by just pressing the buttons on the steering column.
- The raised driving position assures an excellent view of the load. The levers are conveniently to hand for the operator.
- Steering-wheel height and angle are easily adjustable. The parking-brake lever is beside the steering column, high up, to give the operator more room and increase his comfort.
- The comfortable adjustable spring-cushioned seat is equipped with inertia safety belt as standard.
- As well as guaranteeing constantly effective braking action, the use of oil bath brakes allows savings on routine servicing costs.

Truck features	C4E250NV	C4E300NV
Adjustable fork width	S	S
Tilting mast	S	S
Controls and instruments		
Hydraulic steering	S	S
Information display	S	S
Sideshift	S	S
Electronic fingertip controls	O	O
Mini-joystick electronic controls	O	O
Driving features		
Electronic regenerative brakes	S	S
Three driving programs	S	S
Curve cut-back speed	S	S
Safety features		
Clear-view mast	S	S
Driver detection system	S	S
Emergency cut-off	S	S
Programmable performance	S	S
Drivers compartment features		
Adjustable seat with safety belt	S	S
Adjustable steering wheel	S	S
Enclosed cab with or without heating	O	O
Maintenance features		
Easy access for maintenance	S	S
Fault diagnosis facility	S	S
Oil bath brakes	S	S
Battery management features		
Battery status indicator	S	S
Battery discharge prevention system	S	S
Lateral battery extraction	O	O

S = Standard feature

O = Optional feature

— = Not available



The product complies with the EC-directives



BT  
 SE-595 81 Mjölby Sweden  
 Tel: +46 (0)142 860 00  
 Fax: +46 (0) 142 866 00  
 Email: info@bt-forklifts.com  
 www.bt-forklifts.com