

C4E250V
C4E300V
C4E300VL
C4E350V



The Cargo C4E250V-350V is an electric truck which combines high manoeuvrability — even in confined spaces — with the advantages of the alternative current (AC) technology. The agility of this truck is enhanced by electronic control of all functions, making the C4E250V-350V a high performance fork lift for high productivity. Lifting capacity from 2500kg up to 3500kg.



Technical Details	C4E250V	C4E300V	C4E300VL	C4E350V ¹⁾	
Power unit	electric			electric	
Operating type	driver seated			driver seated	
Rated capacity	kg	2500	3000	3000	3500 3300
Load centre	mm	500	500	500	500 500
Load per axle without load, front/rear	kg	2450/2320	2445/2655	2500/2650	2760/2900 2475/2875
Load per axle with load, front/rear	kg	6520/750	7300/800	7250/900	8290/870 7650/1000
Number of wheels, front/rear		2-4/2	2-4/2	2-4/2	2/2 2/2
Wheel type, front/rear ²⁾		C/SE/PN/SE.TW	C/SE/SE.TW	C/SE/SE.TW	C SE/SE.TW
dimension, front		559x229/23x9-10/ 23x9-10/6,50-10	559x229/23x10- 12/6,50-10	559x229/23x10- 12/6,50-10	559x254 23x10-12/ 6,5-10
dimension, rear		457x152/18x7-8/ 18x7-8/18x7-8	457x152/18x7-8/ 18x7-8	457x152/18x7-8/ 18x7-8	457x152 18x7-8
Centre of wheels, front	mm	960/980/980/1152	960/942/1152	960/942/1152	973 942/1150
Centre of wheels, rear	mm	940/940/940/940	940/940/940/940	940/940/940/940	940 940
Fork arm carriage acc. to ISO-FEM		II A	III A	III A	III A III A
Travel speed, without/with rated load	km/h	17,0/17,0	17,0/17,0	17,0/17,0	17,0/17,0 17,0/17,0
Service brake	hydraulic			hydraulic	
Parking brake	foot brake			foot brake	
Lift speed, without/with rated load	m/s	0,50/0,34	0,50/0,32	0,50/0,32	0,47/0,30 0,50/0,31
Lowering speed, without/with rated load	m/s	< 0,60	< 0,60	< 0,60	< 0,60 < 0,60
Nom. drawbar pull, without/with load	N	3400/2000	2840/1840	2830/1810	2740/1640 2830/1810
Max. drawbar pull, without/with load (S2 5')	N	11858/10922	11793/10793	11784/10773	11700/10600 11784/10773
Gradient, without/with rated load (S2 30')	%	10,0/6,0	9,0/5,0	9,0/5,0	8,0/4,2 9,0/5,0
Max. gradient, without/with rated load (S2 5')	%	28,0/17,0	24,0/14,0	24,0/14,0	21,7/12,4 24,0/14,0
Drive motor	kW	14	14	14	14 14
Lift motor	kW	14	14	20	20 20
Battery capacity	V/Ah	80/500-620	80/500-620	80/625-775	80/625-775 80/625-775
Battery weight	kg	1547	1547	1872	1872 1872
Weight with battery	kg	4770	5100	5150	5660 5350
Steering system	hydraulic			hydraulic	
Speed control	electronic			electronic	
Working pressure for attachments	bar	130	130	130	130 130

Dimensions, mm	C4E250V	C4E300V	C4E300VL	C4E350V ¹⁾	
x Front axle to fork face	430 ³⁾	435 ³⁾	435 ³⁾	448 ³⁾	435 ³⁾
y Wheel base	1555	1555	1699	1699	1699
α/β Mast tilt forward/backward	2°30'/10°	2°30'/10°	2°30'/10°	2°30'/10°	2°30'/10°
h ₆ Height overhead guard	2145	2145	2190	2190	2190
h ₇ Height of driver's seat	1090	1090	1090	1090	1090
l ₂ Truck length incl. back of fork	2265	2340	2415	2498	2485
b ₁ Chassis, width	1190 (1530) ⁴⁾	1190 (1530) ⁴⁾	1190 (1530) ⁴⁾	1227	1190
s Fork thickness	40	45	45	50	45
e Fork width	120	120	120	150	120
l Fork length	1000	1000	1000	1000	1000
m ₁ Floor clearance under mast	140	140	140	140	140
m ₂ Floor clearance mid wheelbase	122	122	122	122	122
A _{st} Aisle width, mm					
Pallet size 800x1200/1000x1200 ⁵⁾	3979/3779 ³⁾	4040/3840 ³⁾	4123/3923 ³⁾	4193/3993 ³⁾	4180/3980 ³⁾
W _a Turning radius	2149	2205	2288	2345	2345

1) Cushion resp. Superelastic wheels

2) C = Cushion, SE = Superelastic, PN = Pneumatic, TW = Twin

3) With side shift = +36mm

4) Figures in brackets = twin wheels

5) Shortside handling / longside handling

Mast, mm	Duplex				Duplex FFL		Triplex				Triplex FFL				
h_3 Lift height	3160	3660	4160	4960	2930	3160	4305	4965	5565	6765	4310	4460	4960	5560	6060
C4E250V															
h_1 Height of mast, min.	2252	2502	2752	3202	2132	2252	2132	2352	2552	3052	2132	2182	2352	2552	2752
h_2 Free lift	100	100	100	100	1437	1557	45	45	45	45	1437	1487	1657	1857	2057
h_4 Height of mast, max.	3805	4305	4805	5632	3625	3855	4972	5632	6232	7532	5005	5155	5655	6255	6755
C4E300V, C4E300VL, C4E350V															
h_1 Height of mast, min.	2252	2502	2752	3202	2132	2252	2132	2352	2552	3052	2132	2182	2352	2552	2752
h_2 Free lift	100	100	100	100	1436	1556	45	45	45	45	1436	1486	1656	1856	2056
h_4 Height of mast, max.	3833	4333	4833	5633	3626	3856	4978	5638	6238	7532	5006	5156	5656	6256	6756

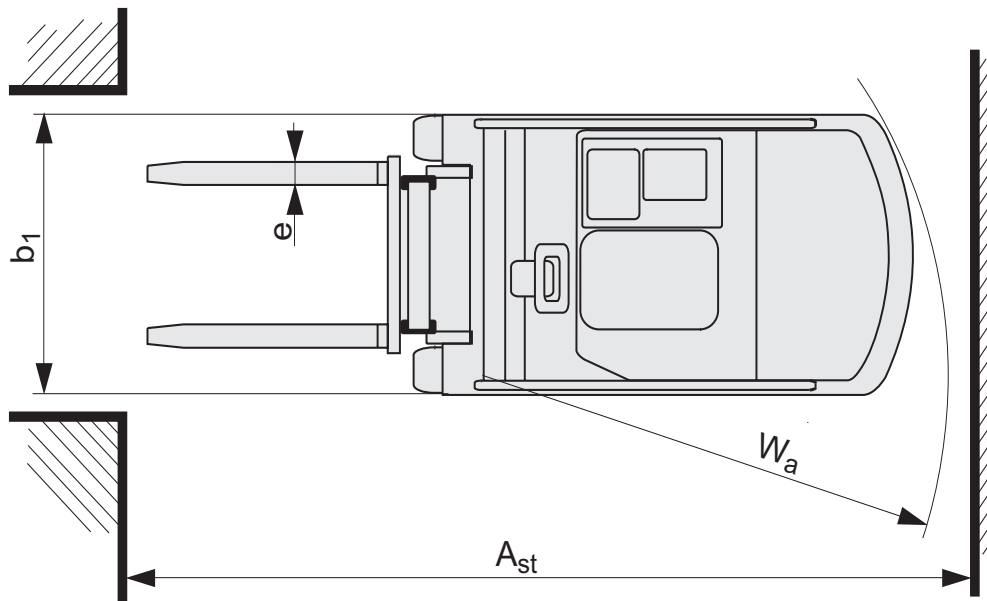
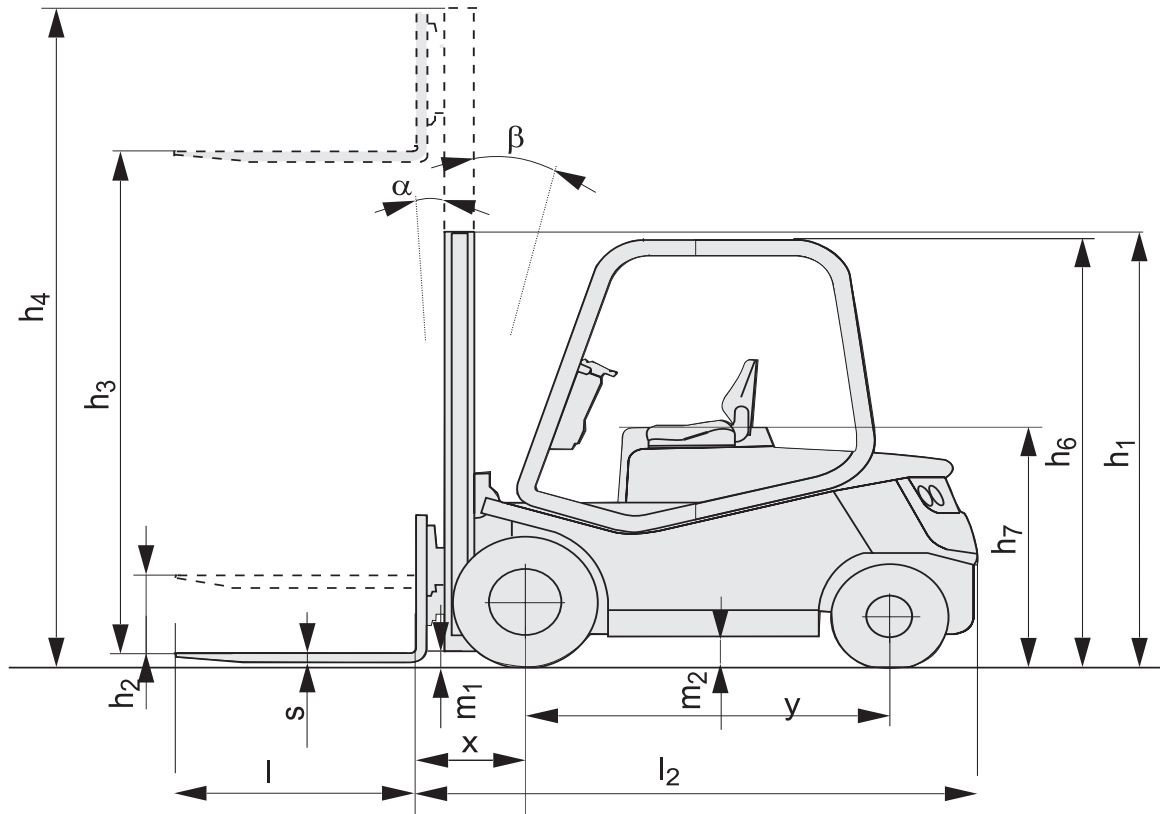

Truck performance and dimensions are nominal and subject to tolerances.
 BT Products AB products and specifications are subject to change without notice.
 All data is based on VDI 2198.



- AC power means exceptional performance levels, combined with reduced energy consumption and lower service and maintenance requirements.
- High visibility and stability. The position of the uprights, which are widely spaced, guarantees excellent visibility and at the same time gives a rigid structure even at great height. Equipped with integrated side-shift as standard.
- Various drive programs can be selected by simply pressing the push-buttons on the steering column. The operator can choose between 3 different drive programs, as well as an additional reduced speed setting.
- The steering wheel is fully adjustable in height/angle and the automobile-style dashboard has main function indicator lights plus error codes display for a rapid fault identification. The release lever of the parking brake is located on the steering column.
- The Can-Bus simplifies the electrical system by reducing wiring and increases the flexibility of the truck control system.
- The overhead guard is fully suspended on silent block elements.
- As well as guaranteeing constantly effective braking action, the use of oil bath brakes allows savings on routine servicing costs.

Truck features	C4E250V	C4E300V	C4E300VL	C4E350V
Adjustable fork width	S	S	S	S
Tilting mast	S	S	S	S
Twin drive tyres	O	O	O	O
High capacity battery models	O	O	S	O
Controls and instruments				
Hydraulic steering	S	S	S	S
Sideshift	S	S	S	S
Information display	S	S	S	S
Electronic fingertip controls	O	O	O	O
Mini-joystick electronic controls	O	O	O	O
Driving features				
Electronic regenerative brakes	S	S	S	S
Three driving programs	S	S	S	S
Safety features				
Clear-view mast	S	S	S	S
Emergency cut-off	S	S	S	S
Programmable performance	S	S	S	S
Drivers compartment features				
Adjustable steering wheel	S	S	S	S
Enclosed cab with or without heating	O	O	O	O
Maintenance features				
Easy access for maintenance	S	S	S	S
Fault diagnosis facility	S	S	S	S
Oil bath brakes	S	S	S	S
Battery management features				
Battery status indicator	S	S	S	S
Battery discharge prevention system	S	S	S	S
Special applications				
Coldstore version	O	O	O	O
EEx version (ATEX)	O	O	O	O

S = Standard feature

O = Optional feature

— = Not available



The product complies with the EC-directives

BT
 SE-595 81 Mjölby Sweden
 Tel: +46 (0)142 860 00
 Fax: +46 (0) 142 866 00
 Email: info@bt-forklifts.com
 www.bt-forklifts.com

