

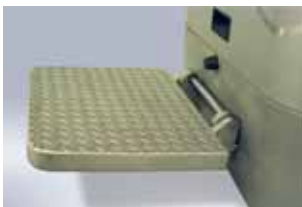

## Pedestrian Pallet Truck

### Stainless steel — with platform

The ORION Range with modern styling is ideally suited for high performance applications. The LPE200I is especially designed for use in food processing or pharmaceutical industry with its high demands in corrosive production environment and standards of hygiene. The truck material is AISI304 (W. No. 1.4301 or SS2333) with all outside surfaces glass blasted.



- The **comfortable steering arm**, with its modern design, facilitates one hand operation — either left or right hand. The display on the handle gives useful information.
- Choice of having **PIN Code** (up to 10) instead of key. Provides access control. Each code can store individual parameters to meet the driver's skill / environment.
- The **BT POWERDRIVE system**. The unique integration of contactless controls, CAN-Bus communication and a separately excited drivemotor gives many advantages. The contactless controls give smooth and effortless driving. The CAN-Bus communication provides quick, reliable transmission and only a few communication cables are needed. The separately excited drivemotor allows easy programming of its performance — top speed, acceleration and automatic speed reduction — to suit the application.
- **Regenerative braking**, energy back to the battery.
- The **spring loaded, anti-slip, foldable platform** enables the driver to work in tight situations and to ride over long distances for maximum comfort and efficiency.
- The truck is equipped with a modified **POWERTRAK** drive unit configuration. The drive unit automatically and constantly adjusts the drive wheel pressure to match the weight of the load. The result is excellent stability, unrivalled traction and an overall improvement in speed and work rate.
- Exceptional **battery power** with capacities available up to 300Ah. Battery compartment increases in height instead of thickness — effects neither the compactness nor the turning radius.
- Easy upwards and sideways **battery exchange** for continuous operation shift after shift. (Sideways exchange only for 240Ah).



Technical Details		LPE200I
Power unit		electrical, battery
Rated capacity	kg	2000
Load centre	mm	600
Weight without battery	kg	555
Max. axle pressure drive wheel, without/with rated load	kg	370/570
Max. axle pressure castor wheels, without/with rated load	kg	135+135/240+240
Max. axle pressure fork wheels, single, without/with rated load	kg	80+80/875+875
Castor wheels, Vulkollan	mm	Ø 125x40
Fork wheels, single/bogie, Vulkollan	mm	Ø 85x95/Ø 85x75
Drive wheel, Vulkollan, 75 shore	mm	Ø 215x70
Travel speed, without/with rated load	km/h	6.0/6.0
Lift speed fork, without/with rated load	m/s	0.07/0.05
Lowering speed fork, without/with rated load	m/s	0.07/0.08
Gradient, without/with rated load	%	18/8
Service-/parking brake		electrical
Drive motor/Intermittent rating	kW/%	1.7/60
Lift motor/Intermittent rating	kW/%	2.2/5
Battery capacity, (5h discharge), min.—max.	V/Ah	24/240—24/300
Battery weight, min.—max.	kg	175—275
Steering system		steering arm
Speed control, number of steps		stepless
Steering arc	°	180

Dimensions, mm		LPE200I
x	Back of fork to bogie wheel centre, fork raised/lowered	877/947
y	Wheel base, fork raised/lowered	1328/1398
h <sub>3</sub>	Lift height	225
h <sub>7</sub>	Platform height	180
h <sub>14</sub>	Height of handle in neutral pos.	1400
h <sub>13</sub>	Height of lowered fork	85
l <sub>2</sub>	Truck length incl. back of fork, platform up/down	693/1073
b <sub>1</sub>	Chassis, width	790
e	Fork width	150
l	Fork length, in 50 mm steps	1000—1400
b <sub>5</sub>	Width across fork	490/540/655
m <sub>1</sub>	Floor clearance	39
A <sub>st</sub>	Aisle width, min., platform up/down (Pallet 800x1200 mm)	2114/2484
W <sub>a</sub>	Turning radius, platform up/down	1661/2031

Data is based on standard battery compartment, medium size, l=1150mm

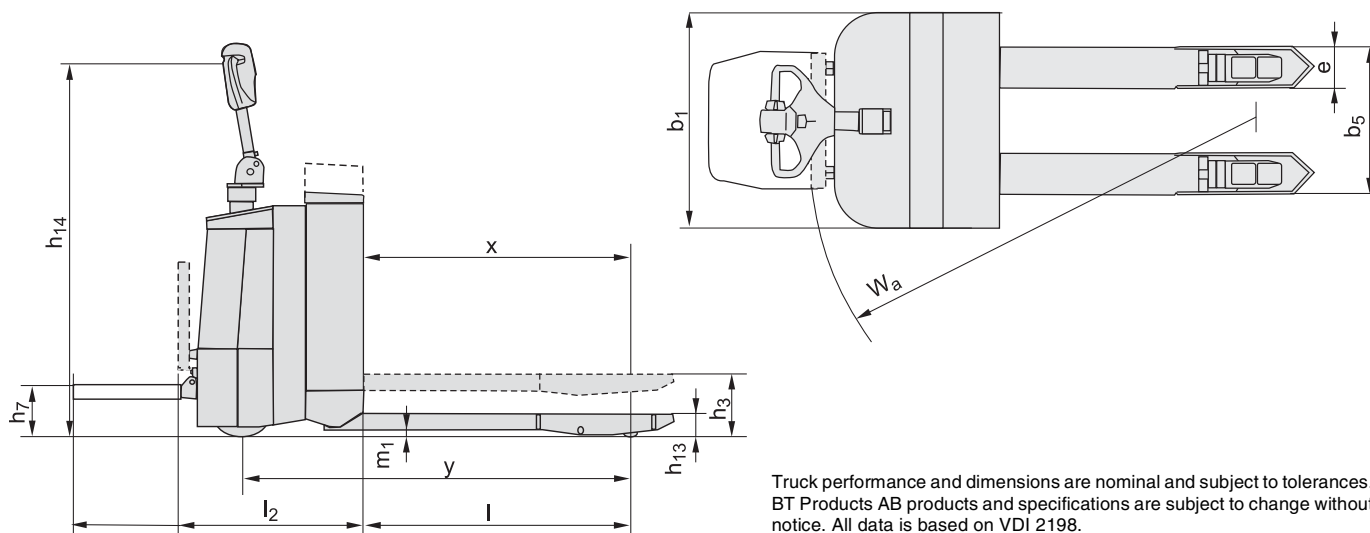

Truck performance and dimensions are nominal and subject to tolerances. BT Products AB products and specifications are subject to change without notice. All data is based on VDI 2198.

# Why BT stainless steel trucks?

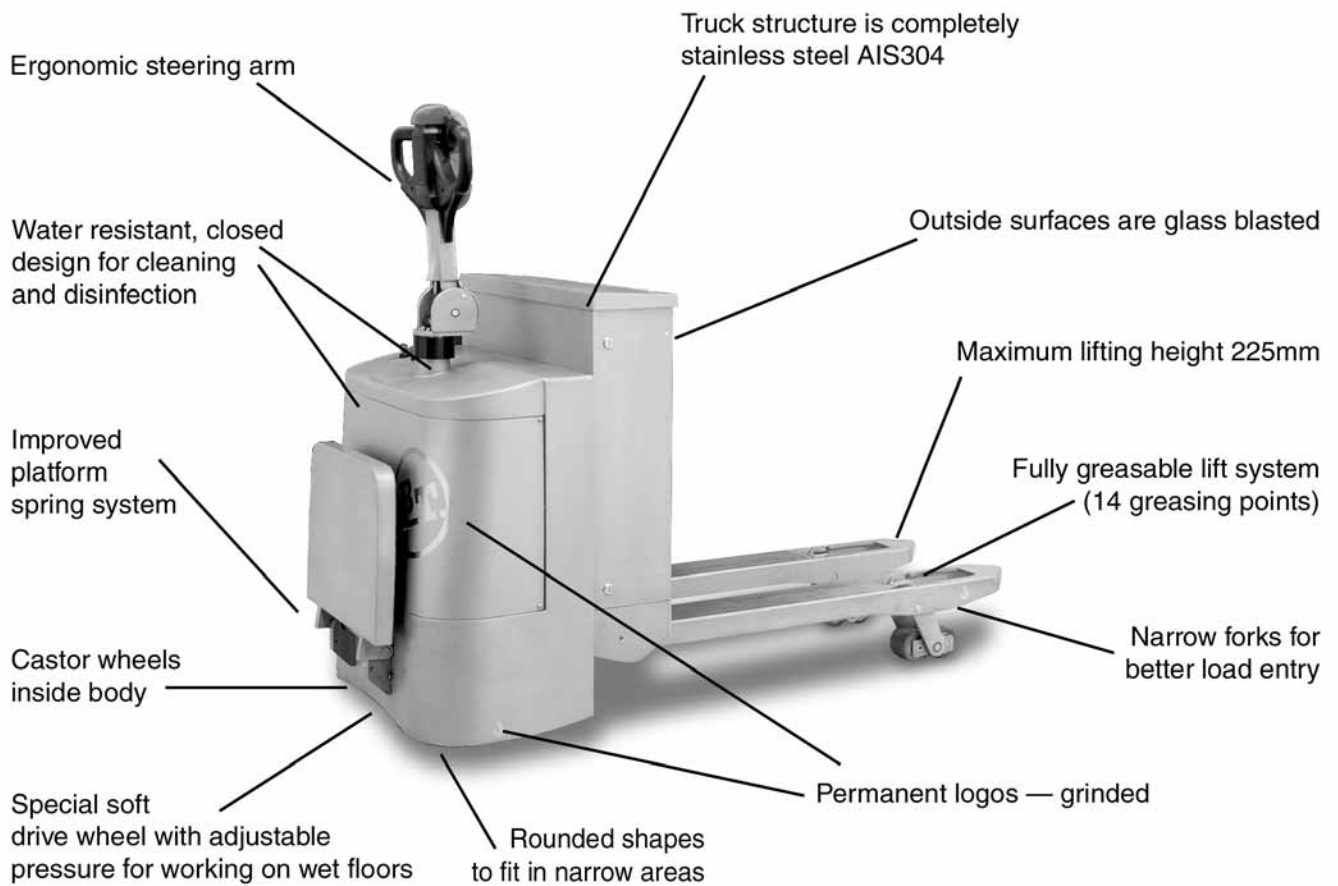



## Options

- Battery change table (carbon steel)
- Change plugs for spare battery
- Gearbox oil and hydraulic oil with USDA H1-certificate.
- Climber wheels (only for single fork wheels) allow better pallet entry



BT  
SE-595 81 Mjölby Sweden  
Tel: +46 (0)142 860 00  
Fax: +46 (0) 142 866 00  
Email: [info@bt-forklifts.com](mailto:info@bt-forklifts.com)  
[www.bt-forklifts.com](http://www.bt-forklifts.com)

