



The BT Minimover is a small and handy electric pallet truck powered with a SEM (Separately Excited Motor), designed for all types of horizontal pallet movements in light applications. It is the ideal upgrade from a hand pallet truck.



Technical Details		LWE130
Rated capacity	kg	1300 / 3000 lbs*
Load centre	mm	600
Weight without battery	kg	200
Max. axle load drive wheel, without/with rated load	kg	175 / 570
Max. axle load castor wheels, without/with rated load	kg	2 x 30 / 2 x 24
Max. axle load fork wheels, without/with rated load	kg	18+18 / 496+496
Castor wheels, polyurethane	mm	Ø 100 x 40
Fork wheels, single, polyurethane	mm	Ø 85 / Ø 75*
Drive wheel, Tractothan	mm	Ø 250 x 60
Travel speed, without/with rated load	km/h	5.5 / 4
Lift speed, without/with rated load	m/s	0.07 / 0.04
Lowering speed, without/with rated load	m/s	0.04 / 0.04
Gradient, without/with rated load	%	10 / 5
Service-/parking brake		electromagnetic
Drive motor/short-time rating (S2 60')	kW	0.5
Lift motor/Intermittent rating (S3 10%)	kW	1.2
Steering system		steering arm
Speed control, number of steps		transistor, stepless
Steering arc	°	208

Dimensions, mm		LWE130
x	Back of fork to single wheel centre, fork raised (l=1150 / 1070*)	937 / 840*
y	Wheel base, fork raised/lowered (l=1150)	1199,1252 / 1100*,1168*
h ₃	Lift height	205 / 195*
h ₁₄	Height of handle in neutral pos.	1270
h ₁₃	Height of lowered fork	85 / 75*
b ₁	Chassis, width	700
l ₂	Truck length incl. back of fork	420
e	Fork width	156
l	Fork length	910,1000,1150 / 910*,1070*, 1220*
b ₅	Width across fork	450 / 520 / 685
m ₁	Floor clearance	48
A _{st}	Aisle width, min (Pallet 800x1200 mm)	1873 / 1820*
W _a	Turning radius	1410 / 1328*

Battery and charger		LWE130
Battery capacity	Ah	63
Battery charger	A	8
Voltage	V	2 x 12
Battery weight	kg	2 x 23

Performance may vary due to motor and system efficiency tolerance and represents nominal values obtained under typical operating conditions.
BT Products AB products and specifications are subject to change without notice.
Datas are based on VDI 2198.

* = Only available on the North American market.

Minimover

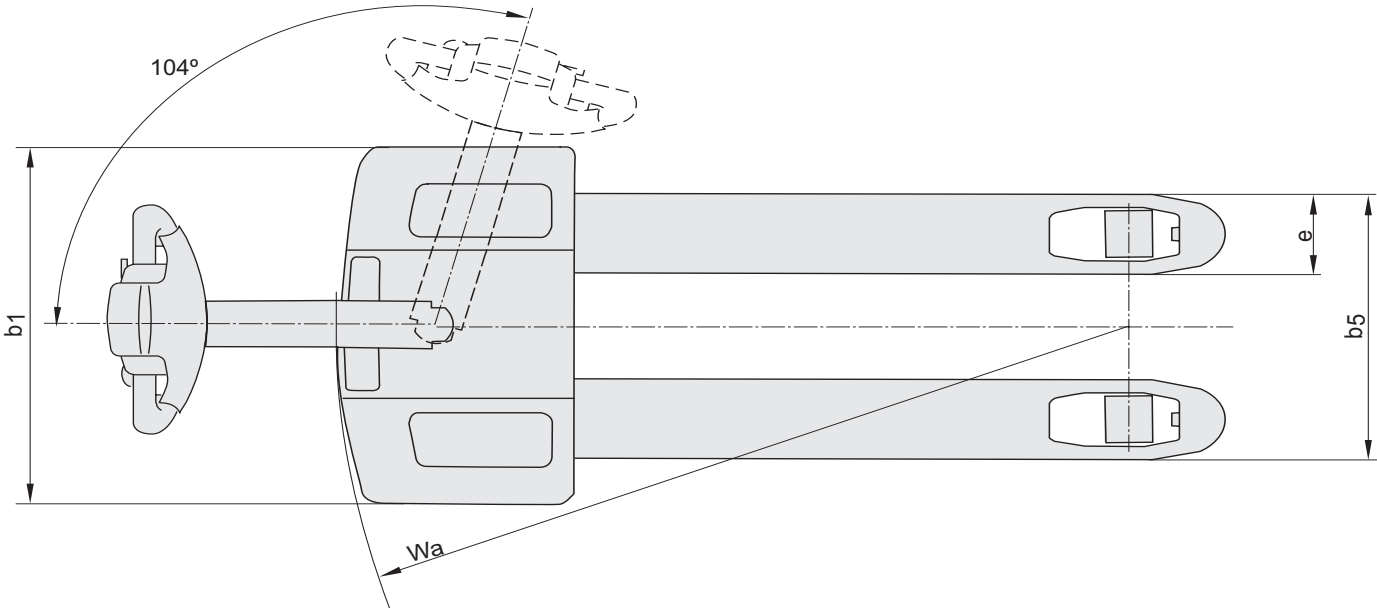
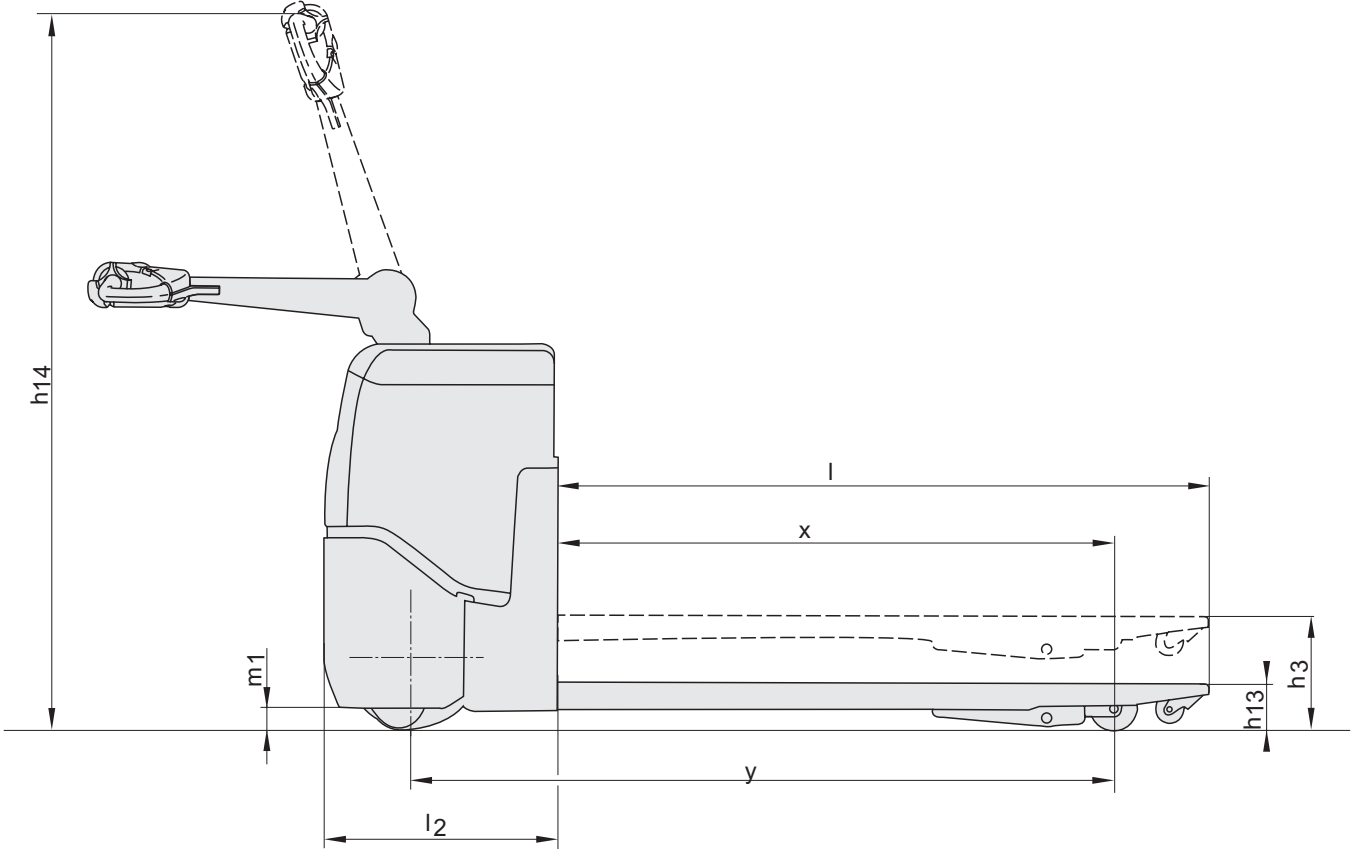



- The Minimover is suitable for use e.g. in retail operations, manufacturing sites and on vehicles with tail-lift.
- The Minimover is compact and sturdy with the capacity of 1300kg. The compact chassis width is only 700mm and the machine length only 420mm. In combination with 208° steering this makes the Minimover an exceptionally manoeuvrable truck, perfect for use in confined areas.
- Built-in charger for easy charging. 63 Ah batteries, 2 x 12 V.
- Choice of three different forkwidths, and three choices of forklenghts.
- Forks fitted with greasable bushings to allow easy maintenance and extended operation life.
- Climber wheels are standard with singel wheels. Allows effective pallet entry regardless of pallet type.
- In-vehicle charging possibility for use in 24 V vehicles.

Truck features	LWE130
Bogie fork wheels	O
Castor link system	S
Climber wheels	S
Storage compartments	S
Controls and instruments	
Fingertip controls	S
Tiller arm steering	S
Driving features	
208° steering	S
Electronic braking system	S
Electronic speed control	S
Safety features	
Automatic parking brake	S
Emergency collision button	S
Emergency cut-off	S
Load support	O
Maintenance features	
Fault diagnosis facility	S
History fault log	S
Battery management features	
Built-in charger	S
In-vehicle charging	O
Battery indicator	O

S = Standard feature

O = Optional feature

— = Not available

ITS, Sweden — 745200-040, 0609

