

SHM080  
SHL080



Ideal for small stores which require low-frequency and relatively low-level stacking. Ideal for block stacking or for use in racking. Available in manual or electric lift versions. Maximum lift capacity 800kg, maximum lift height 1600mm.



Technical Details		SHM080
Rated capacity	kg	800
Weight	kg	255
Support arm wheels, nylon	mm	Ø 75x75
Steering wheels, nylon	mm	Ø 200x50

Dimensions, mm		SHM080
x	Front axle to fork face	740
y	Wheel base	1165
$h_{14}$	Height of handle in neutral pos.	1290
$h_{13}$	Height of lowered fork	86
$l_2$	Truck length incl. back of fork	525
$b_1$	Chassis, width	770
s	Fork thickness	55
e	Fork width	160
l	Fork length	1150
$b_5$	Width across fork	540
$m_2$	Floor clearance mid wheelbase	25
$A_{st}$	Aisle width, min (Pallet 800x1200 mm)	1930
$W_a$	Turning radius	1210

Mast, mm		SHM080
$h_3$	Lift height	1600
$h_1$	Mast height, min.	1990
$h_2$	Free lift	1600
$h_4$	Mast height, max.	1990

Truck performance and dimensions are nominal and subject to tolerances. BT Products AB products and specifications are subject to change without notice. VAll data is based on VDI 2198.

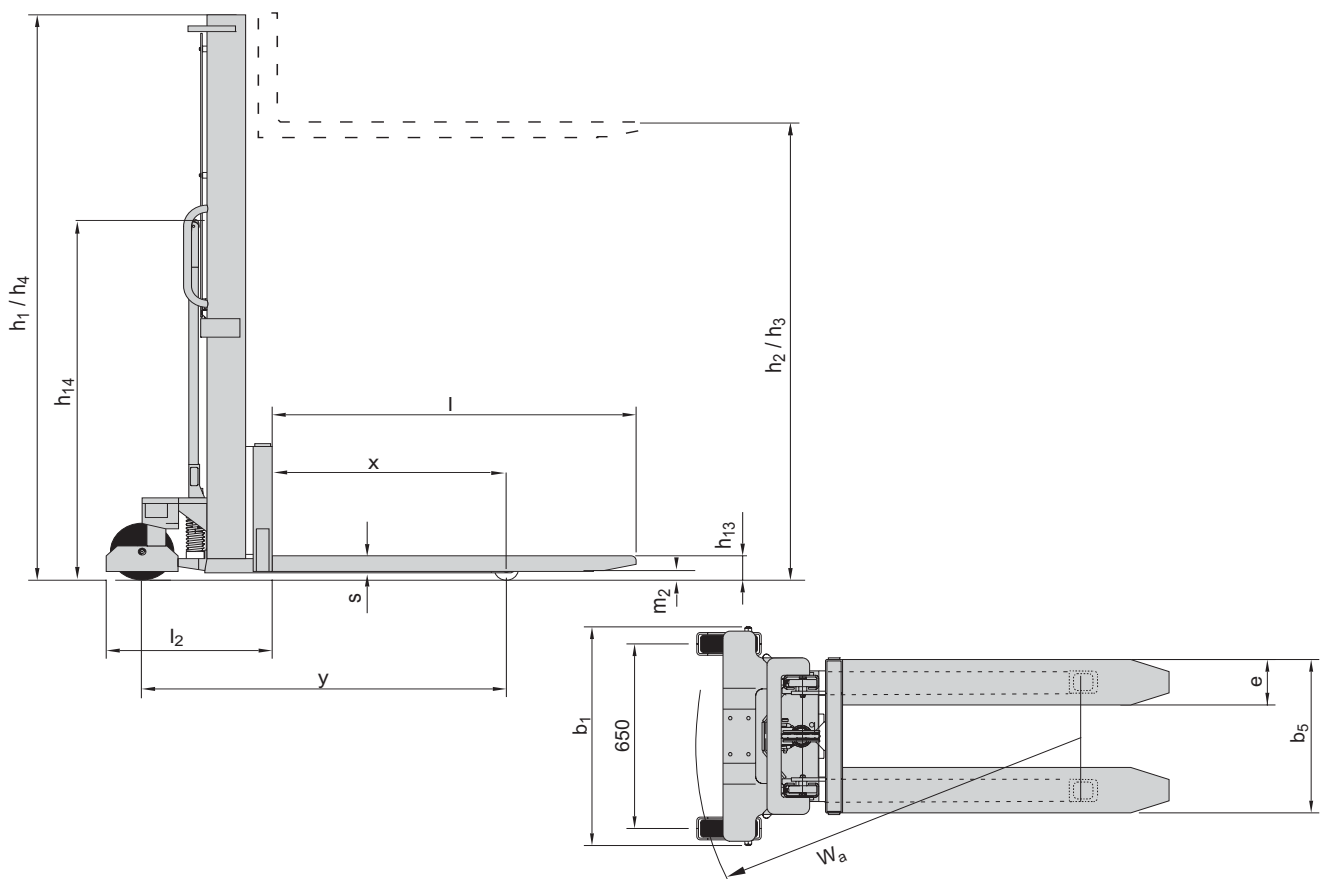

Technical Details		SHL080
Power unit		Battery
Rated capacity	kg	800
Weight without battery	kg	295
Support arm wheels, nylon	mm	Ø 75x75
Steering wheels, nylon	mm	Ø 200x50
Lift motor	kW	0.8
Battery, min.	V/Ah	12/110

Dimensions, mm		SHL080
x	Front axle to fork face	740
y	Wheel base	1165
$h_{14}$	Height of handle in neutral pos.	1355
$h_{13}$	Height of lowered fork	86
$l_2$	Truck length incl. back of fork	525
$b_1$	Chassis, width	770
s	Fork thickness	55
e	Fork width	160
l	Fork length	1150
$b_5$	Width across fork	540
$m_2$	Floor clearance mid wheelbase	25
$A_{st}$	Aisle width, min (Pallet 800x1200 mm)	1930
$W_a$	Turning radius	1210

Mast, mm		SHL080
$h_3$	Lift height	1600
$h_1$	Mast height, min.	1990
$h_2$	Free lift	1600
$h_4$	Mast height, max.	1990

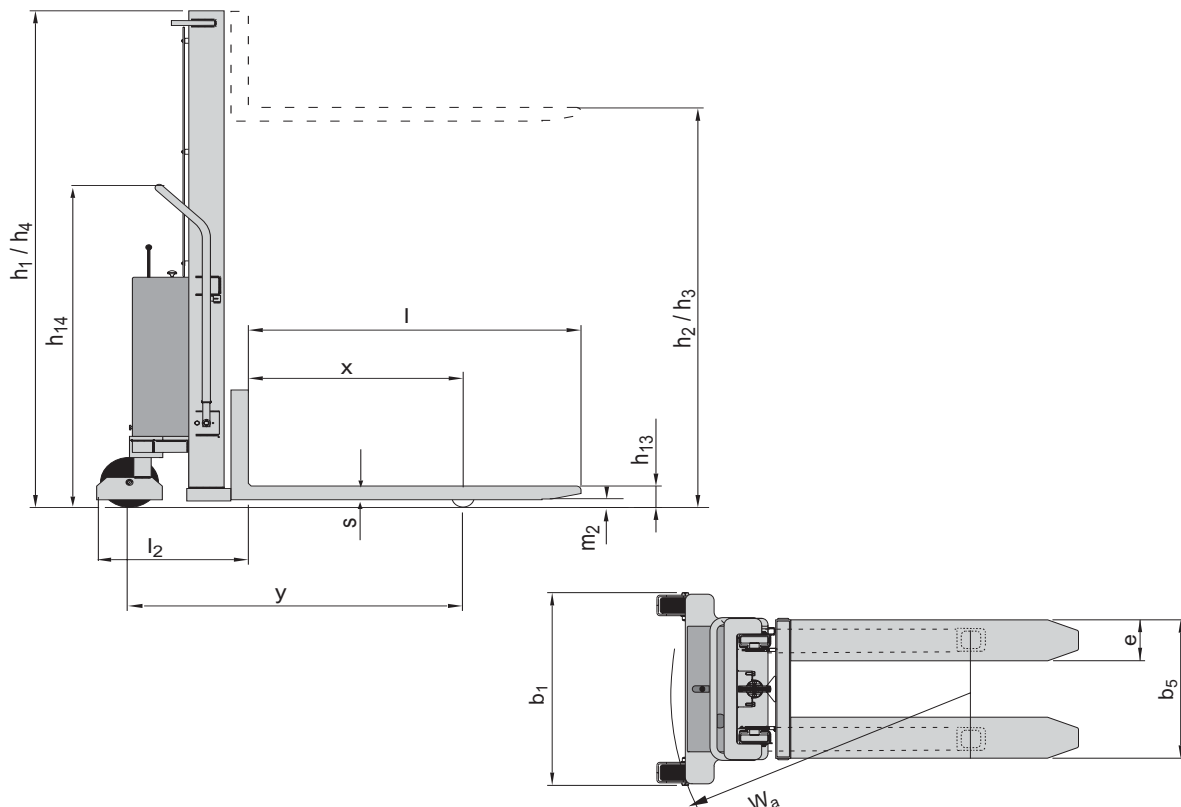



- Clearview mast design allows exceptional visibility when pushing and placing / retrieving the load.
- Pinch protecting device at the steering wheels and parking brake allow safer working environment.
- Robust forks with extra reinforcement minimize bending down for heavy loads.
- The Ministacker is equipped with wide support arms that straddle the load, allowing operation with a variety of different pallet sizes.
- Wide support arms can be combined with adjustable forks.

### SHM080 — Manual

- QUICKLIFT-function as standard with automatic transfer to normal lift with loads over 200kg.

### SHL080 — Electric

- Mechanical lowering valve gives a precise and controlled lowering.

Truck features	SHM080	SHL080
Quick-lift function	S	—
Choice of wheel types	—	—
Choice of fork lengths	—	—
Choice of chassis widths	—	—
Controls and instruments		
Tiller arm steering	S	S
Safety features		
Emergency cut-off	—	S
Parking brake	S	S

S = Standard feature

O = Optional feature

— = Not available