



SPE125 and SPE160 both have fixed support arms and lift heights up to 5400 mm. The machines are built for horizontal transport and stacking in intensive applications that require durable high capacity trucks.



Technical Details		SPE125	SPE160
Operating type		pedestrian/stand on	pedestrian/stand on
Rated capacity	kg	1250	1600
Load centre	mm	600	600
Max. axle load drive wheel, without/with rated load	kg	390/530	390/620
Max. axle load castor wheel, without/with rated load	kg	600/630	640/610
Max. axle load supp.wheels, without/with rated load	kg	340/1420	410/1810
Travel speed, without/with rated load/without platform	km/h	8/7/6	8/7/6
Lift speed, without/with rated load	m/s	0.29/0.19 <sup>1)</sup>	0.22/0.15 <sup>1)</sup>
Lowering speed, without/with rated load	m/s	0.40/0.55 <sup>1)</sup>	0.25/0.49 <sup>1)</sup>
Gradient, without/with rated load	%	12/10	12/10
Service-/parking brake		1 stage electromagnetic brake	1 stage electromagnetic brake
Drive motor/Intermittent rating (S2 60')	kW	1.7	1.7
Lift motor/ Intermittent rating (S3 11%)	kW	3	3
Steering system		steering arm	steering arm
Speed control		transistor, stepless	transistor, stepless
Steering arc	°	180	180

Dimensions, mm		SPE125	SPE160
x	Back of fork to bogie wheel centre	833 <sup>2)</sup>	786
y	Wheel base	1440	1440
	Drive wheel movement up/down	15/30	15/30
	Drive wheel, Powerfriction <sup>3)</sup>	Ø 215	Ø 215
	Castor wheels, Vulkollan	Ø 125x50	Ø 125x50
	Support arm wheels, bogie, Vulkollan	Ø 85x75	Ø 85x75
h <sub>7</sub>	Platform height	150	150
l <sub>4</sub>	Platform length	400	400
h <sub>14</sub>	Height of handle in neutral pos.	1435 <sup>4)</sup>	1435 <sup>4)</sup>
h <sub>13</sub>	Height of lowered fork	90	90
l <sub>2</sub>	Truck length incl. fork face, without/with platform up/down	830/860/1287 <sup>5)</sup>	877/907/1334
b <sub>1</sub>	Chassis, width	790/850/1150	790/850/1150
s	Fork thickness	65	70
e	Fork width	180	180
l	Fork length	800/900/1000/1150/1400	1150/1400
b <sub>5</sub>	Width across fork	450/520/570/685	570/685
m <sub>1</sub>	Floor clearance under mast	24	24
A <sub>st</sub>	Aisle width, without/platform up/down	2253/2283/2685	2253/2283/2685
W <sub>a</sub>	Turning radius, without/with platform up/down	1686/1716/2143	1686/1716/2143

Data is based on small size battery compartment, l=1150, Duplex Hi-Lo  
Large battery compartment = +98 mm and +30 kg

Mast, SPE125			Duplex Tele			Duplex Hi-Lo					Triplex Hi-Lo					
<b>h<sub>23</sub></b>	<b>Total lift height</b>	<b>mm</b>	<b>2350</b>	<b>2800</b>	<b>3350</b>	<b>2350</b>	<b>2900</b>	<b>3350</b>	<b>3750</b>	<b>4150</b>	<b>3350</b>	<b>3750</b>	<b>4150</b>	<b>4500</b>	<b>4800</b>	<b>5400</b>
h <sub>1</sub>	Height of mast, min.	mm	1710	1935	2210	1710	1985	2210	2420	2620	1680	1815	1950	2065	2165	2365
h <sub>2</sub>	Free lift	mm	—	—	—	1240	1515	1740	1940	2140	1205	1340	1475	1590	1690	1890
h <sub>4</sub>	Height of mast, max.	mm	2870	3320	3870	2870	3420	3870	4280	4680	3875	4275	4675	5025	5325	5925
Weight without battery <sup>6)</sup>		kg	960	980	1010	980	1010	1035	1060	1080	1060	1080	1100	1120	1135	1165
Battery (5h discharge), min./max.		V/Ah	24/180—440													
Battery weight, min./max.		kg	200—250/300—370													

Mast, SPE160			Duplex Tele				Duplex Hi-Lo					Triplex Hi-Lo						
<b>h<sub>23</sub></b>	<b>Total lift height</b>	<b>mm</b>	<b>2350</b>	<b>2900</b>	<b>3350</b>	<b>3750</b>	<b>4150</b>	<b>2350</b>	<b>2900</b>	<b>3350</b>	<b>3750</b>	<b>4150</b>	<b>3350</b>	<b>3750</b>	<b>4150</b>	<b>4400</b>	<b>4800</b>	<b>5400</b>
h <sub>1</sub>	Height of mast, min.	mm	1745	2020	2245	2445	2645	1745	2020	2245	2445	2645	1740	1875	2010	2075	2205	2405
h <sub>2</sub>	Free lift	mm	—	—	—	—	—	1240	1515	1740	1940	2140	1114	1248	1382	1465	1598	1798
h <sub>4</sub>	Height of mast, max.	mm	2900	3450	3900	4300	4700	2900	3450	3900	4300	4700	4005	4405	4805	5055	5455	6055
Weight without battery <sup>6)</sup>		kg	1050	1080	1110	1140	1170	1060	1090	1120	1150	1180	1160	1190	1210	1230	1250	1290
Battery (5h discharge), min./max.		V/Ah	24/180—440															
Battery weight, min./max.		kg	200—250/300—370															

Truck performance and dimensions are nominal and subject to tolerances.  
BT Products AB products and specifications are subject to change without notice.  
All data is based on VDI 2198.

- 1) Based on Triplex mast
- 2) Triplex mast -20 mm
- 3) Other alternatives available
- 4) Height of handle in neutral position without platform 1580 mm, in normal driving position 1040 mm.
- 5) Triplex mast +20 mm
- 6) Platform weight = +30 kg

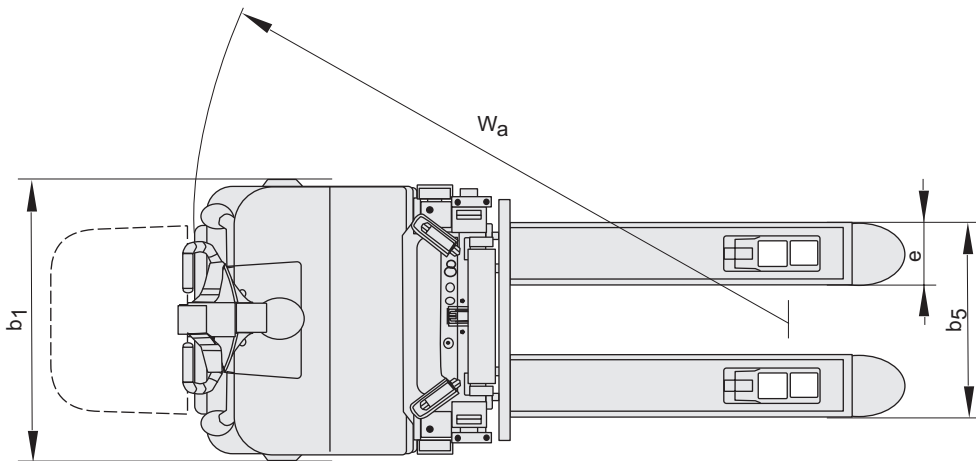
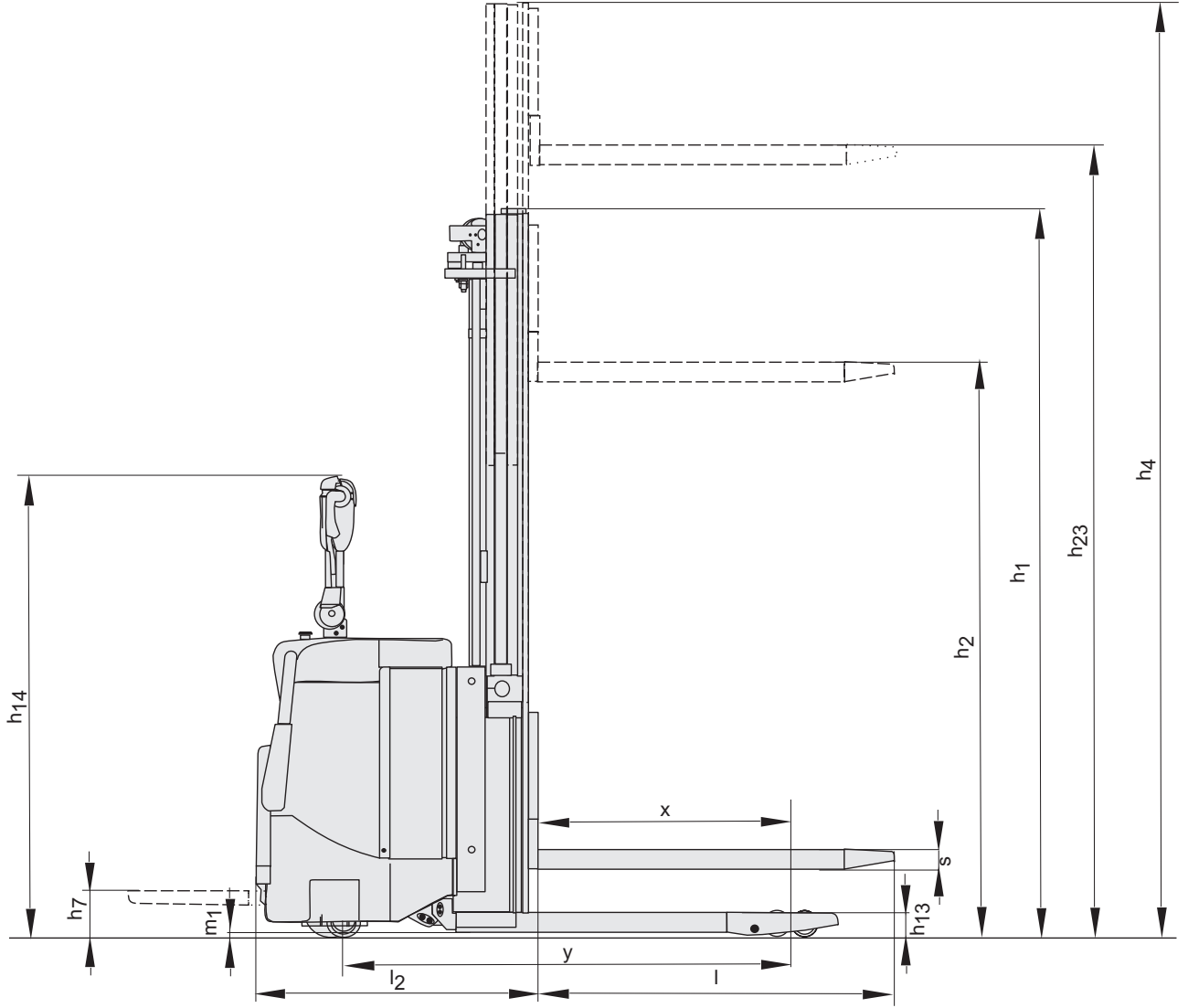

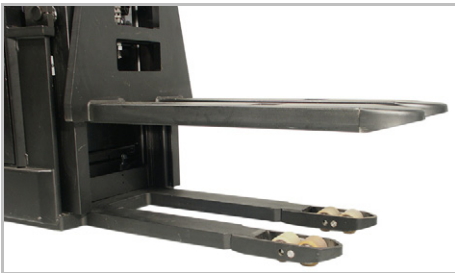

- The truck is equipped with Powertrak drive unit configuration — a BT patent. The drive wheel pressure is constantly adjusted due to the weight of the load. The result is optimal traction and minimum steering force.
- The comfortable steering arm, with its modern design, facilitates one hand operation. The lift, lowering and driving functions are ergonomically placed on the steering arm and can be operated by finger tip force.
- The Sensi-lift function offer precise and intuitive control of the lift and lowering speeds.
- Individual driver parameters, top speed, acceleration and automatic speed reduction, to meet driver skills can be programmed via the key pad (no tool needed).
- The BT Powerdrive system provides reliability and simplicity. Can-bus technology means fewer parts and reliable transmission of data. A Pin code start up procedure offers higher operational safety by stopping unauthorised driving.
- Two different battery compartments provide the truck with excellent flexibility.

Truck features	SPE125	SPE160
BT Powerdrive System	S	S
Powertrak traction system	S	S
<b>Controls and instrument</b>		
Fingertip controls	S	S
Information display	S	S
Power/Electronic steering	O	O
Sensi-lift	S	S
Temporary speed reduction (turtle button)	O	O
Tiller arm steering	S	S
<b>Driving features</b>		
180° steering	S	S
Electronic braking system	S	S
Electronic speed control	S	S
Flip-down driver platform	S	S
<b>Safety features</b>		
BT Access Control	S	S
Clear-view mast	S	S
Folding sideguards	S	S
Programmable performance	S	S
<b>Maintenance features</b>		
Easy access for maintenance	S	S
Fault diagnosis facility	S	S
<b>Battery management features</b>		
Battery change facility	O	O
Battery status indicator	S	S
Heavy duty battery compartments	O	O
Sideways battery change	O	O
<b>Special applications</b>		
Coldstore version	O	O

S = Standard feature

O = Optional feature