

SPE200
SPE200L



SPE200 and SPE200L are high capacity stackers built for horizontal transport and stacking in applications that require durable trucks with a high safety level.



Technical Details		SPE200	SPE200L
Operating type		pedestrian	pedestrian
Rated capacity	kg	2000	2000
Rated capacity, support arm lift	kg	—	2000
Load centre	mm	600	600
Max. axle load drive wheel, without/with rated load/ with rated load on support arms	kg	400/595/—	400/595/595
Max. axle load castor wheels, without/with rated load/ with rated load on support arms	kg	670/665/—	690/685/685
Max. axle load support arm wheels, without/with rated load/ with rated load on support arms	kg	410/2220/—	410/2220/2220
Travel speed	km/h	6	6
Lift speed, without/with rated load	m/s	0,22/0,13	0,22/0,13
Lowering speed, without/with rated load	m/s	0,25/0,44	0,25/0,44
Gradient, without/with rated load	%	12/10	12/10
Service-/parking brake		1 stage electromagnetic brake	1 stage electromagnetic brake
Drive motor/Intermittent rating (S2 60')	kW	1,7	1,7
Lift motor/ Intermittent rating (S3 11%)	kW	3	3
Steering system		steering arm	steering arm
Speed control		transistor, stepless	transistor, stepless
Steering arc	°	180	180

Dimensions, mm		SPE200	SPE200L
x	Back of fork to bogie wheel centre, fork raised	781	720
y	Wheel base, fork raised/lowered	1440	1421/1481
	Drive wheel movement up/down	15/30	15/30
	Drive wheel, Powerfriction ¹⁾	Ø 215	Ø 215
	Castor wheels, Vulkollan	Ø 125x50	Ø 125x50
	Support arm wheels, bogie, Vulkollan	Ø 85x75	Ø 85x75
h ₇	Platform height	150	150
l ₄	Platform length	400	400
h ₁₄	Height of handle in neutral pos.	1435 ²⁾	1435 ²⁾
h ₁₃	Height of lowered fork	90	90
l ₂	Truck length incl. fork face, without/with platform up/down	882/912/1339	923/953/1380
b ₁	Chassis, width	850/1150	850/1150
s	Fork thickness	70	70
e	Fork width	180	180
l	Fork length	1150	1150
b ₅	Width across fork	570	570
m ₁	Floor clearance	24	24
A _{st}	Aisle width, without/platform up/down	2640/2490/2917	2534/2464/2691
W _a	Turning radius, without/with platform up/down	1681/1711/2138	1709/1739/2166

Data is based on small size battery compartment, b₁ = 1150 mm, Duplex Hi-Lo
Large battery compartment = +98 mm and +30 kg

Mast, mm			Duplex Tele					Duplex Hi-Lo				
h₂₃	Total lift height	mm	2150	2700	3150	3550	3950	2150	2700	3150	3550	3950
h ₁	Height of mast, min. ³⁾	mm	1745	2020	2245	2445	2645	1745	2020	2245	2445	2645
h ₂	Free lift ³⁾	mm	—	—	—	—	—	1140	1415	1640	1840	2040
h ₄	Height of mast, max.	mm	2800	3350	3800	4200	4600	2800	3350	3800	4200	4600
	Weight without battery ⁴⁾	kg	1030	1060	1110	1150	1160	1040	1070	1120	1160	1170
	Battery (5h discharge), min./max. V/Ah		24/180—440									
	Battery weight, min./max.	kg	200—250/300—370									

- 1) Other alternatives available
- 2) Height of handle in neutral position without platform = 1580 mm,
in normal driving position = 1040 mm.
- 3) +120 mm with raised support arms
- 4) Platform weight 30 kg

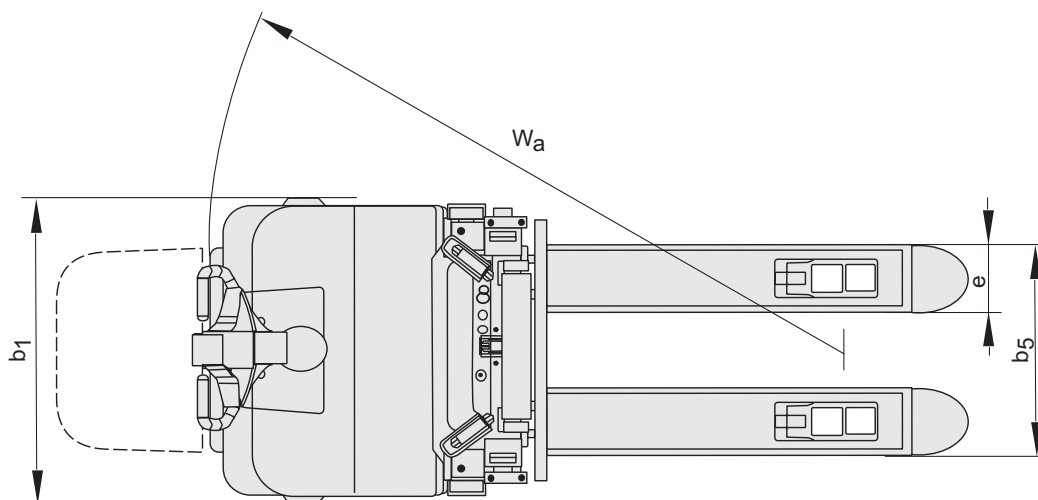
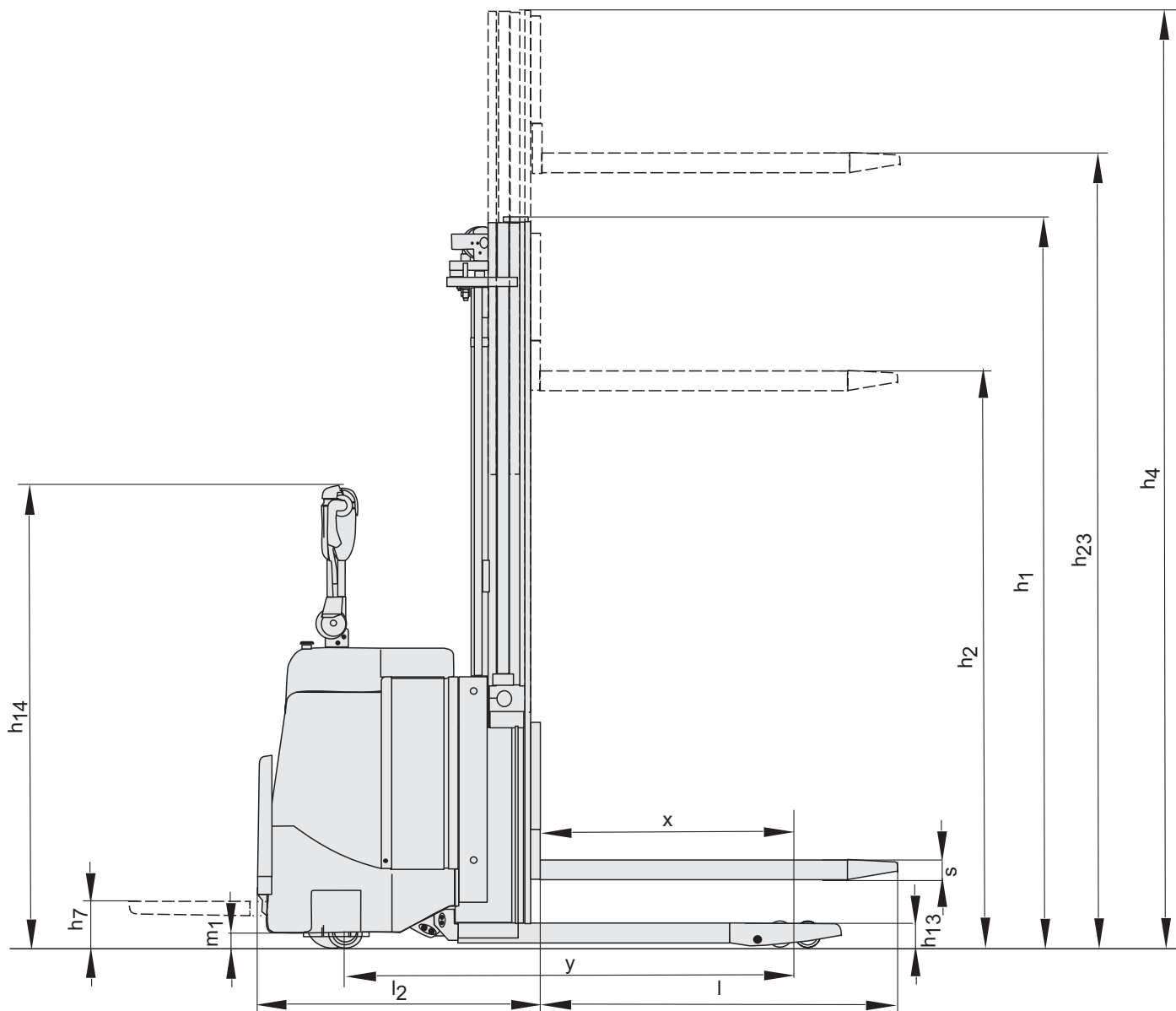



- The 2000 kg stackers are available in two models. One with fixed support arms for handling on even surfaces. The other model, with elevating support arms, can be used on ramps and uneven surfaces and also for double pallet handling.
- The truck is equipped with Powertrak drive unit configuration — a BT patent. The drive wheel pressure is constantly adjusted due to the weight of the load. The result is optimal traction and minimum steering force.
- The comfortable steering arm, with its modern design, facilitates one hand operation. The lift, lowering and driving functions are ergonomically placed on the steering arm and can be operated by finger tip force.
- The Sensi-lift function offer precise and intuitive control of the lift and lowering speeds.
- The BT Powerdrive system provides reliability and simplicity. Can-bus technology means fewer parts and reliable transmission of data. A Pin code start up procedure offers higher operational safety by stopping unauthorised driving.
- Two different battery compartments provide the truck with excellent flexibility.

Truck features	SPE200	SPE200L
BT Powerdrive System	S	S
Choice of chassis widths	O	O
Elevating support arms	—	S
Powertrak traction system	S	S
Controls and instrument		
Information display	S	S
Power/Electronic steering	O	O
Sensi-lift	S	S
Temporary speed reduction (turtle button)	O	O
Tiller arm steering	S	S
Driving features		
180° steering	S	S
Electronic braking system	S	S
Electronic speed control	S	S
Flip-down driver platform	S	S
Safety features		
BT Access Control	S	S
Load support	O	O
Programmable performance	S	S
Maintenance features		
Easy access for maintenance	S	S
Fault diagnosis facility	S	S
Battery management features		
Battery change facility	O	O
Battery status indicator	S	S
Heavy duty battery compartments	S	S
Sideways battery change	O	O

S = Standard feature

O = Optional feature

— = Not available

BT
 SE-595 81 Mjölby Sweden
 Tel: +46 (0)142 860 00
 Fax: +46 (0) 142 866 00
 Email: info@bt-forklifts.com
 www.bt-forklifts.com

